

# PDJQ

## AIR CUSHION BELT CONVEYOR

This AIR CUSHION BELT CONVEYOR system uses an air film to suspend the belt and conveyor materials, enabling horizontal or inclined transport of granular and powdery materials. This system includes a head with driving unit, tail and middle sections, air supply, and tensioning devices. By eliminating direct contact between the belt and equipment, it significantly reduces wear and energy consumption.

With fewer bearings, the system offers a low failure rate and minimal maintenance cost. Optional head and tail self-cleaning devices enhance hygiene and performance. Equipped with speed protection, belt alignment, emergency stop, and pressure sensors, it ensures stable operation and equipment safety. Tail and middle section gravity tensioning can be configured based on actual design requirements.

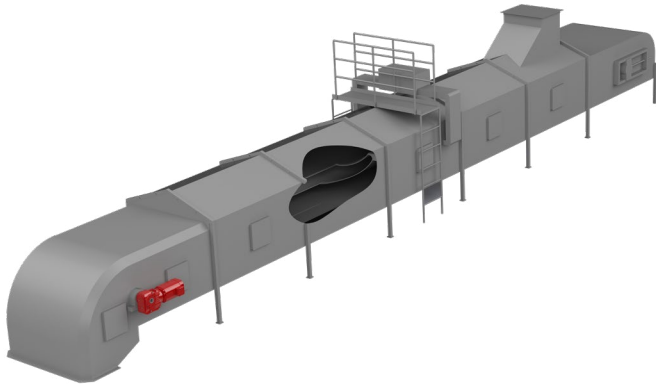

[info@g-grain.com](mailto:info@g-grain.com)

More details please visit [www.g-grain.com](http://www.g-grain.com) and download

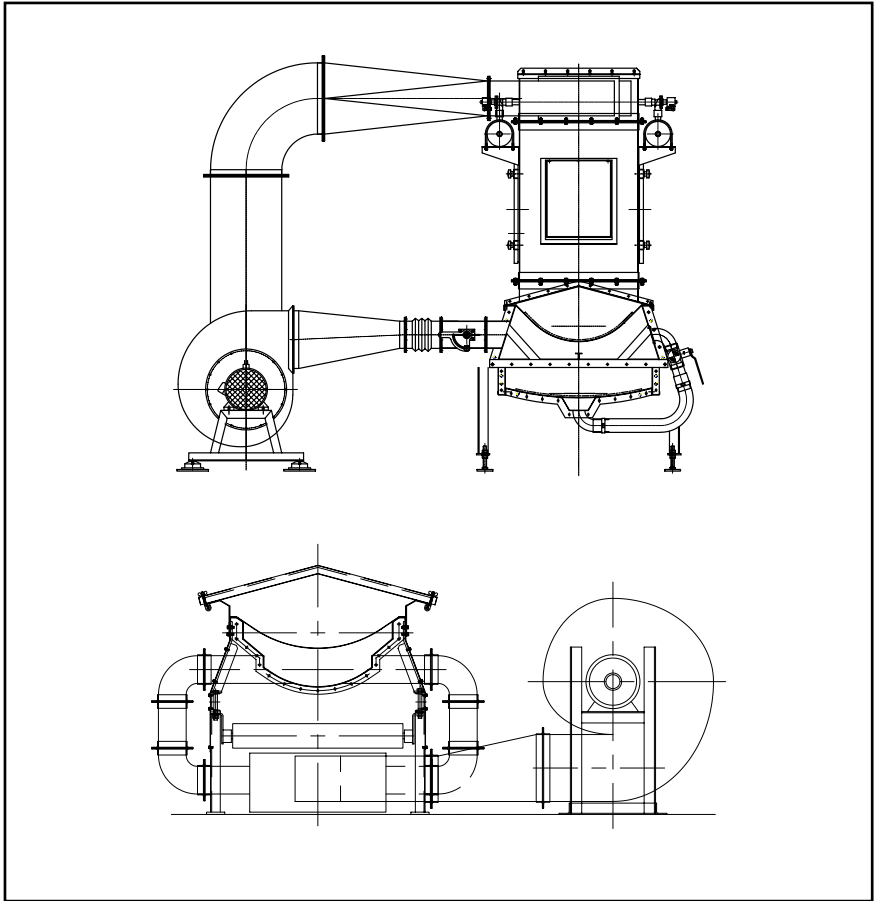

Model	Belt Width (mm)	Belt Speed (m/s)	Capacity (t/h)
PDJQ-65	650	1.6-2.5	150-230
PDJQ-80	800	1.6-3.15	200-400
PDJQ-100	1000	2-3.15	500-800
PDJQ-120	1200	2-3.15	800-1200
PDJQ-140	1400	2-3.15	1000-1600
PDJQ-160	1600	2-3.15	1200-1800

Note: Capacity is based on bulk density 0.75t/m<sup>3</sup>.