

DBZS

SINGLE-SPOUT PACKER

This SINGLE-SPOUT PACKER consists of a rack, screw feeders, twin weighing hoppers, bag holder, pack clamp presser, sewing machine, bag conveyor, load cells, weighing instrument, and an electronic control system. It is mainly used for weighing and packaging bran, fiber-flour mixtures, animal feeds, chemical fertilizers, and other fibrous or powdery materials.

A variable-frequency controller enables fast, medium, and slow feeding modes for the screw feeder, ensuring high weighing accuracy. The instrument provides comprehensive data display and real-time reporting via Profibus. With a capacity of 400–500 bags per hour, low installation height, high precision, and easy maintenance, this packer delivers efficient and reliable performance.

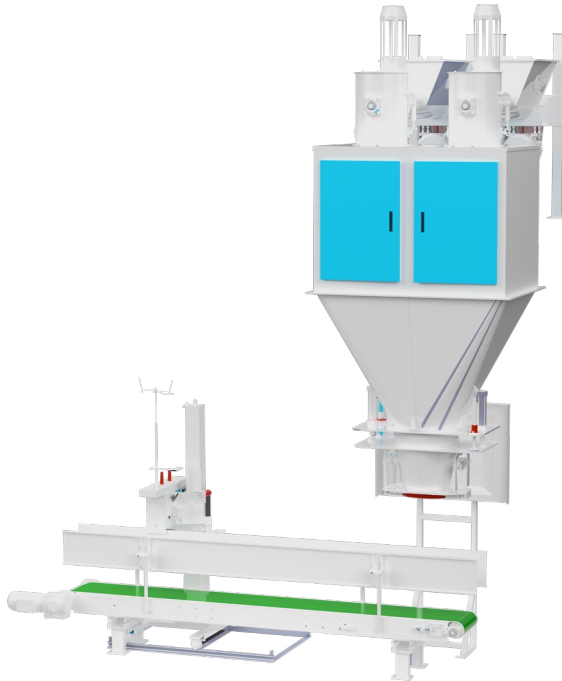

info@g-grain.com

More details please visit www.g-grain.com and download

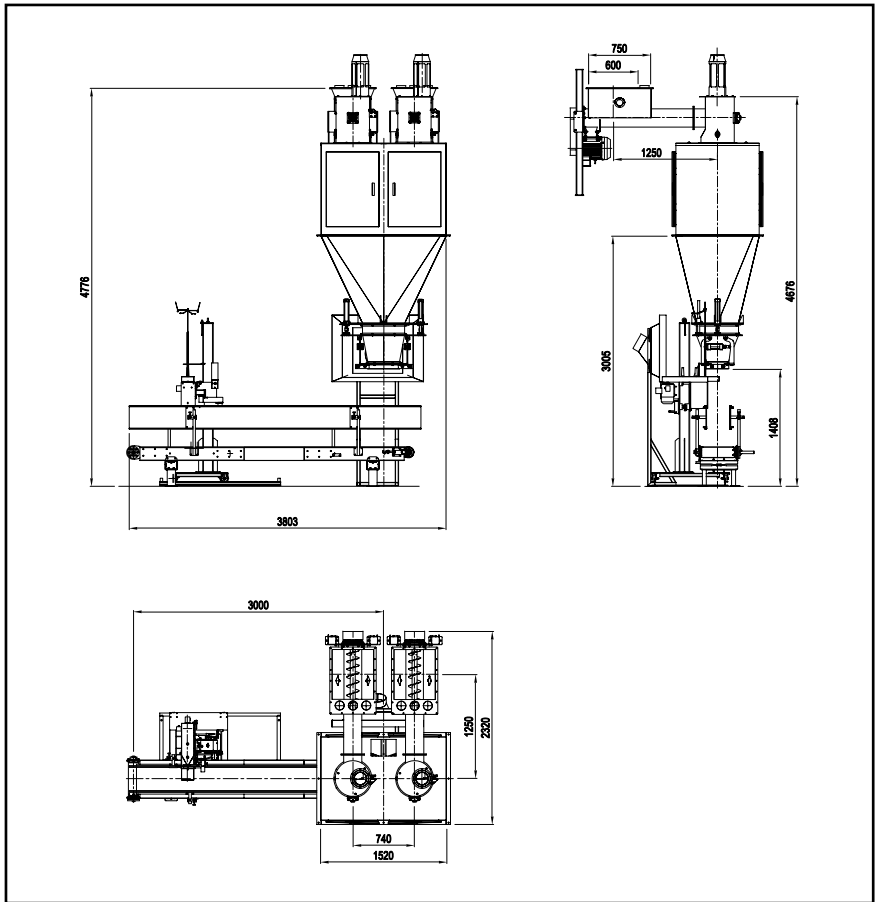

Model	Bag Weight (kg/bag)	Volume (L)	Capacity (bag/h)	Accuracy
DBZS-50J	40	100	450-500	±0.2%

Note: It can be used for bran packaging. The packing speed depends on the weighing system, package weight, material, and operator.