

ZJJ

SERIES CHECK WEIGHER

This SERIES CHECK WEIGHER is a dynamic weighing advanced platform designed for production line quality control. As products pass through the weighing zone, unqualified items are automatically rejected, ensuring strict quality standards and reducing operational costs. The system features a compact design, reliable performance, high accuracy, and enhanced safety. It supports a wide weight inspection range of up to 100 kg, making it suitable for diverse industrial applications.



info@g-grain.com

More details please visit www.g-grain.com and download

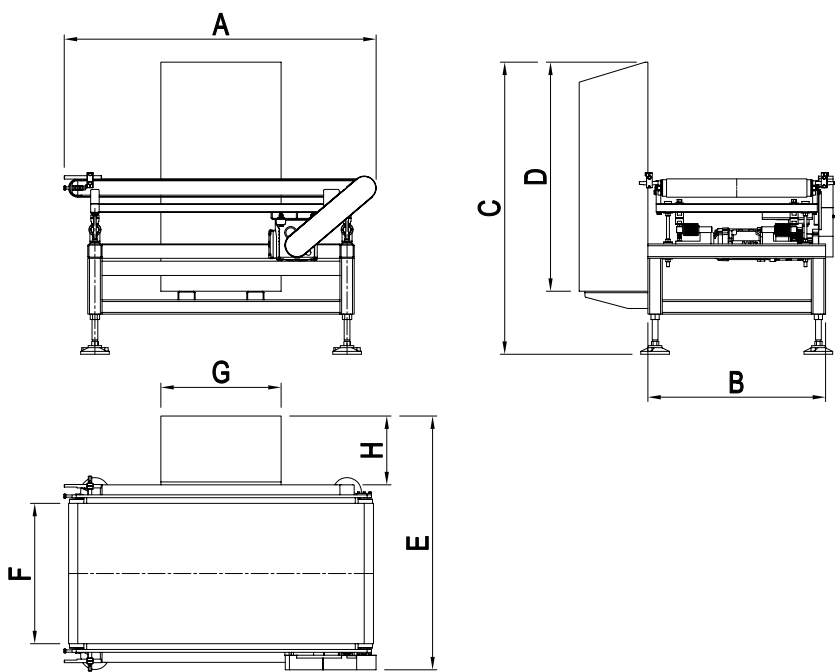

| Model | A (mm) | B (mm) | C (mm) | D (mm) | E (mm) | F (mm) | G (mm) | H (mm) |
|---------|--------|--------|--------|--------|--------|--------|--------|--------|
| ZJJ-40 | 1088 | 620 | 1020 | 800 | 886 | 490 | 420 | 240 |
| ZJJ-100 | 1307 | 620 | 1020 | 800 | 991 | 590 | 420 | 240 |

| Model | Capacity (pcs/min) | Belt Speed (m/min) | Accuracy (3-sigma) | Weighing Scope (kg) | Belt Length | Belt Width | IP Code |
|---------|--------------------|--------------------|--------------------|---------------------|-------------|------------|-----------|
| ZJJ-40 | ≤ 50 | ≤ 45 | ±0.2% | ≤ 40 | 600,800 | 500,400 | IP54/IP65 |
| ZJJ-100 | ≤ 40 | ≤ 65 | ±0.2% | ≤ 100 | 1200 | 600 | IP54 |