

SBZW

DOUBLE-SPOUT PACKER

This DOUBLE-SPOUT PACKER is composed of a feeding screw conveyor, sensor, bag clamp holder, posser, sewing machine, bag conveyor, and electronic and pneumatic control units. It is widely used for the automatic weighing and packing of powdery materials, enabling high-speed operations with precise target weight control.

The system supports filling, sewing (with operator assistance), and conveying, with double spouts, it reduces operator waiting time and significantly boosts packing speed. The control system ensures high accuracy and reliable performance.



info@g-grain.com

More details please visit www.g-grain.com and download

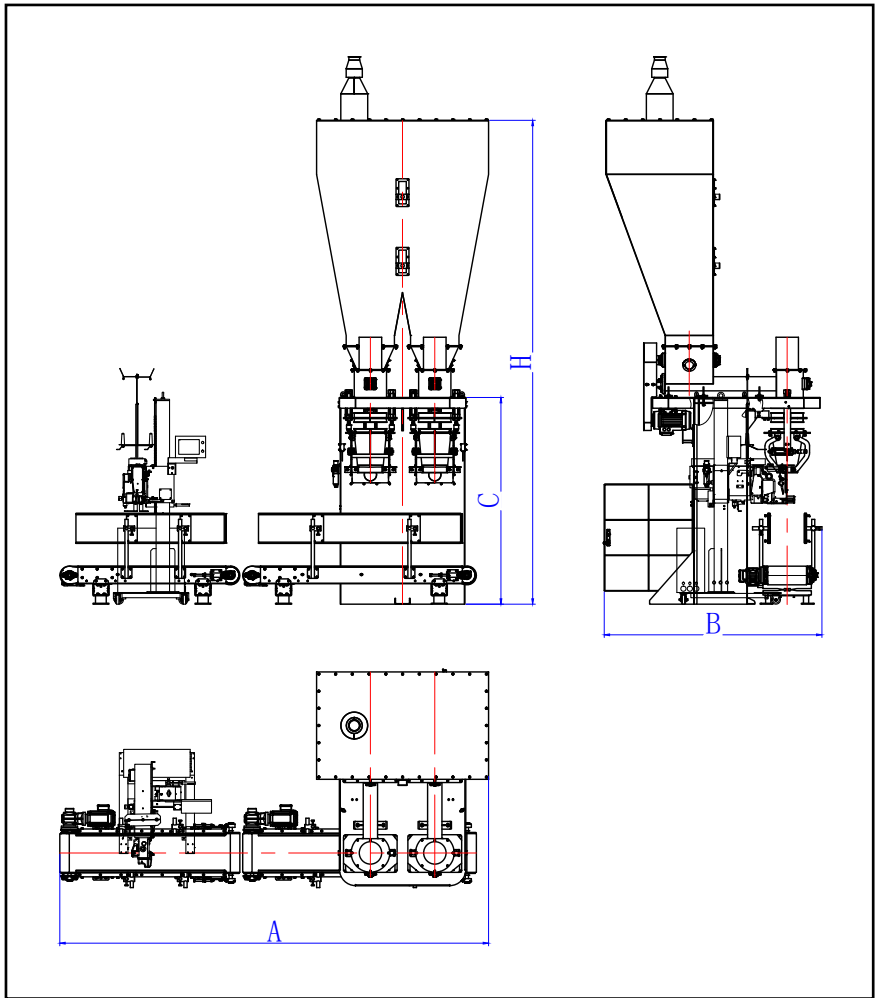

Model	Bag Weight (kg)	Power (kW)	Maximum (bag/h)	Accuracy (%)	Pressure (MPa)	Air Consumption (m ³ /h)	Dimensions (mm)			
							A	B	C	H
SBZW-10	5-10	2.2×2+0.55×2+0.37	600	±0.2	0.5-0.6	4.8-7.2	3091	1578	1705	3320
SBZW-25	15-25	3×2+0.75×2+0.37	500	±0.2	0.5-0.6	4.8-7.2	3391	2008	1925	4506
SBZW-50	40-50	4×2+0.75×2+0.37	400	±0.2	0.5-0.6	4.8-7.2	3837	2331	2025	4626

Note: The packing speed depends on the weighing system, package weight, material, and operator.