

FPBZ

BRAN PACKER WITH TWIN HOPPER SCALE

Structure

FPBZ-40S is composed of a rack, feeding screws, twin weighing hoppers, bag clamp holder, posser, sewing machines, bag conveyor, load cells, weighing instrument and electronic control system.

Application

FPBZ-40S packer is mainly used for weighting and packaging bran, mixtures of fibrous and floury material, feeds, chemical fertilizer and mixtures of fibers and powdery materials etc.

Features

Variable frequency controller controls the screw feeder to realize fast, medium and slow feeding and accurately control the weighing precision.

Weighing instrument with rich data display for operations, profibus module, weighing data and reports real-time. Large weighing range (400-500 bags/h); lower installation height; high accuracy. Easy operation & maintenance.

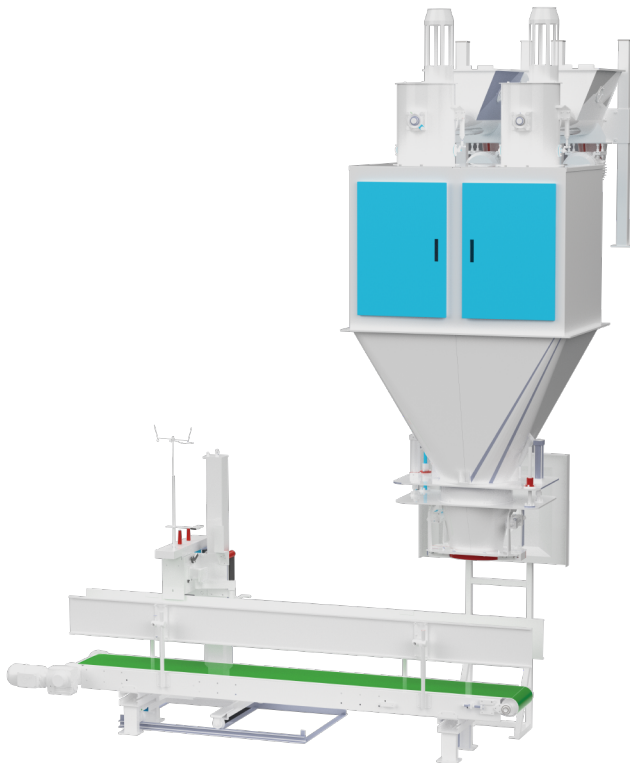

GOLDEN GRAIN

info@g-grain.com

More details please visit www.g-grain.com and download

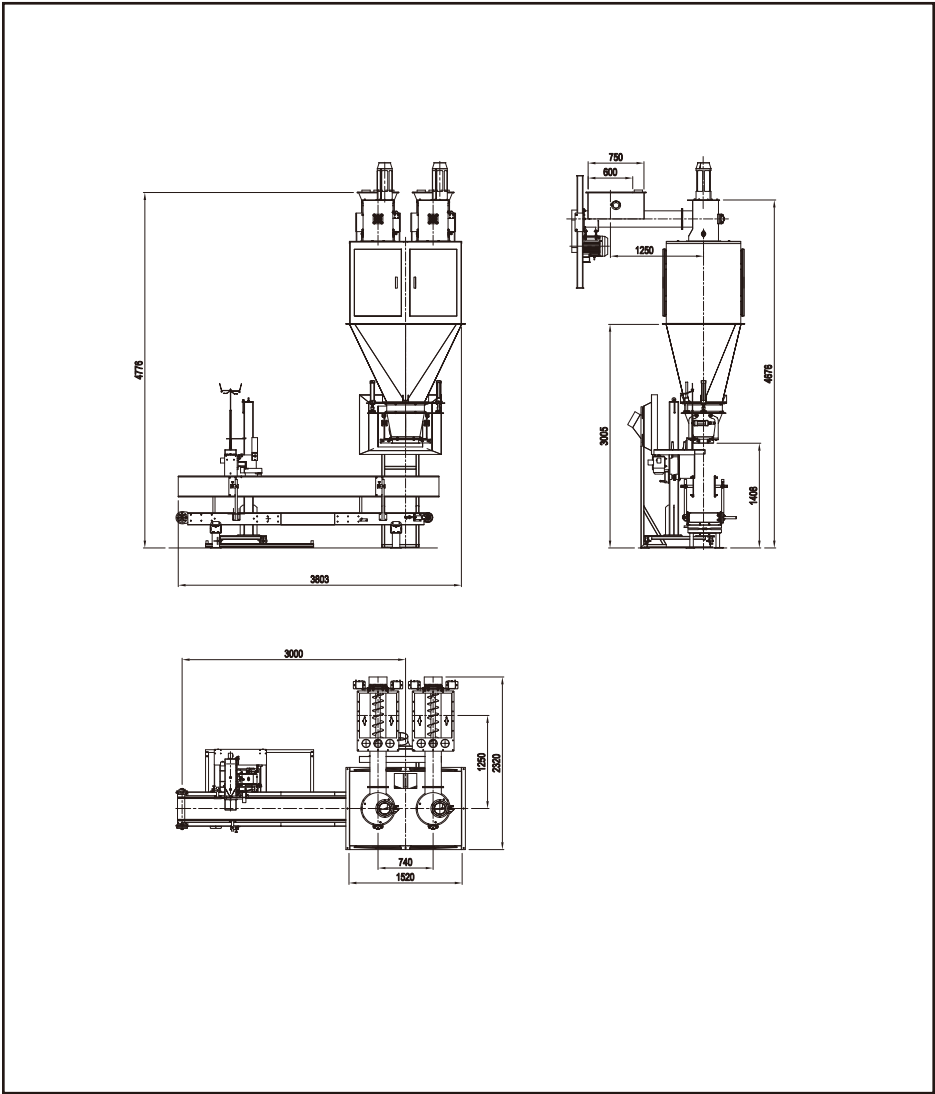

Model	Material density	Bag (kg/bag)	Scale (L)	Feed screw diameter	Capacity (bag/h)	Accuracy
FPBZ-40S	Bran(0.25)	40	170	Φ200	450-500	±0.2%

1)Capacity shall be calculated according to bulk density and scale liter

2)Capacity based on fiber & powder type and on operator