

DBZW

SINGLE-SPOUT PACKER

This SINGLE-SPOUT PACKER consists of a feeding screw conveyor, sensor, bag clamp holder, posser, sewing machine, bag conveyor, and electronic and pneumatic control units. It is widely used for the automatic weighing and packing of powdery materials, enabling high-speed operations with precise target weight control. The system supports filling, sewing (with operator assistance), and conveying.

Its advanced control system ensures high accuracy, stable performance, and reliable operation in demanding industrial environments.



info@g-grain.com

More details please visit www.g-grain.com and download

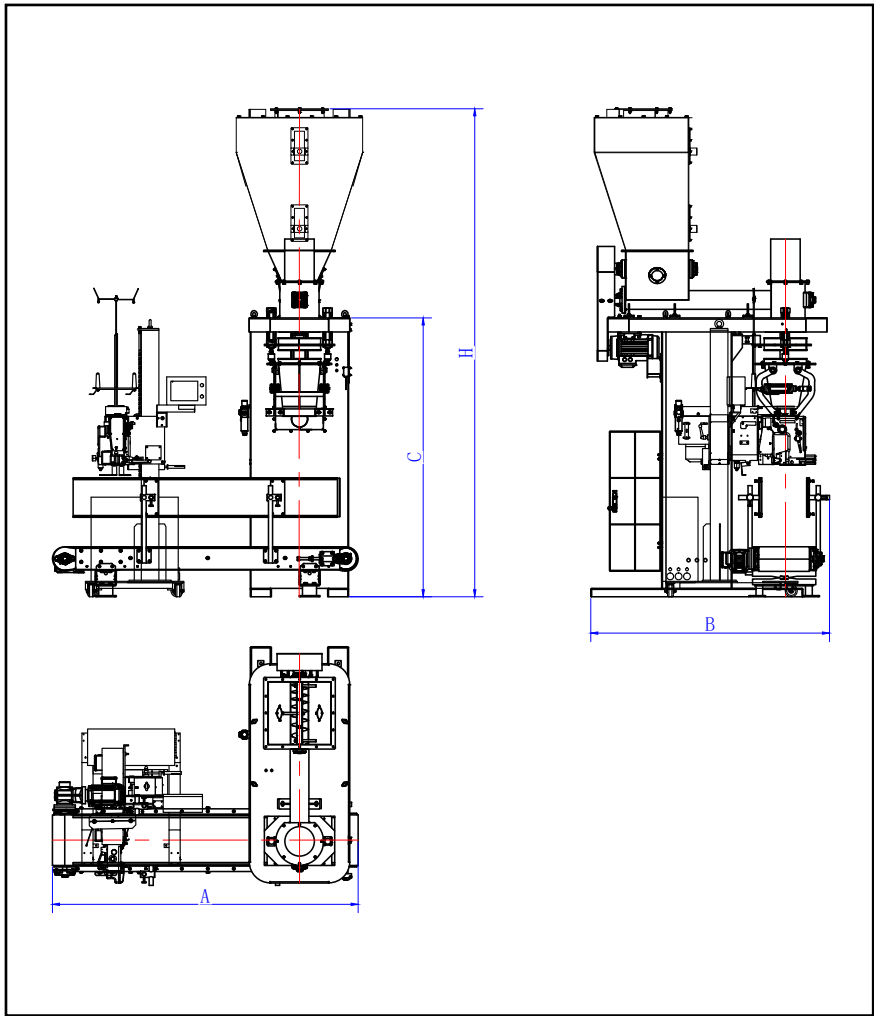

Model	Bag Weight (kg)	Power (kW)	Capacity (bag/h)	Accuracy (%)	Pressure (MPa)	Air Consumption (m ³ /h)	Dimensions (mm)			
							A	B	C	H
DBZW-10	2-10	2.2+0.75+0.37	320-350	±0.2	5-6	2.4-3.6	2175	1579	1705	3219
DBZW-25	15-25	3+0.75+0.37	250-300	±0.2	5-6	2.4-3.6	2175	1699	1985	3469
DBZW-50	25-50	4+0.75+0.37	260	±0.2	5-6	2.4-3.6	3083	1805	2055	3609