

DHJ

MIXER

This MIXER is used for flour blending in the milling process, ensuring uniform consistency across final flour products. The DHJ paddle mixer series is designed for efficient mixing and can also be adapted for premix formulations. Its versatility makes it suitable for both standard flour blending operations and customized product development, supporting innovation and quality control in modern milling systems.



info@g-grain.com

More details please visit www.g-grain.com and download

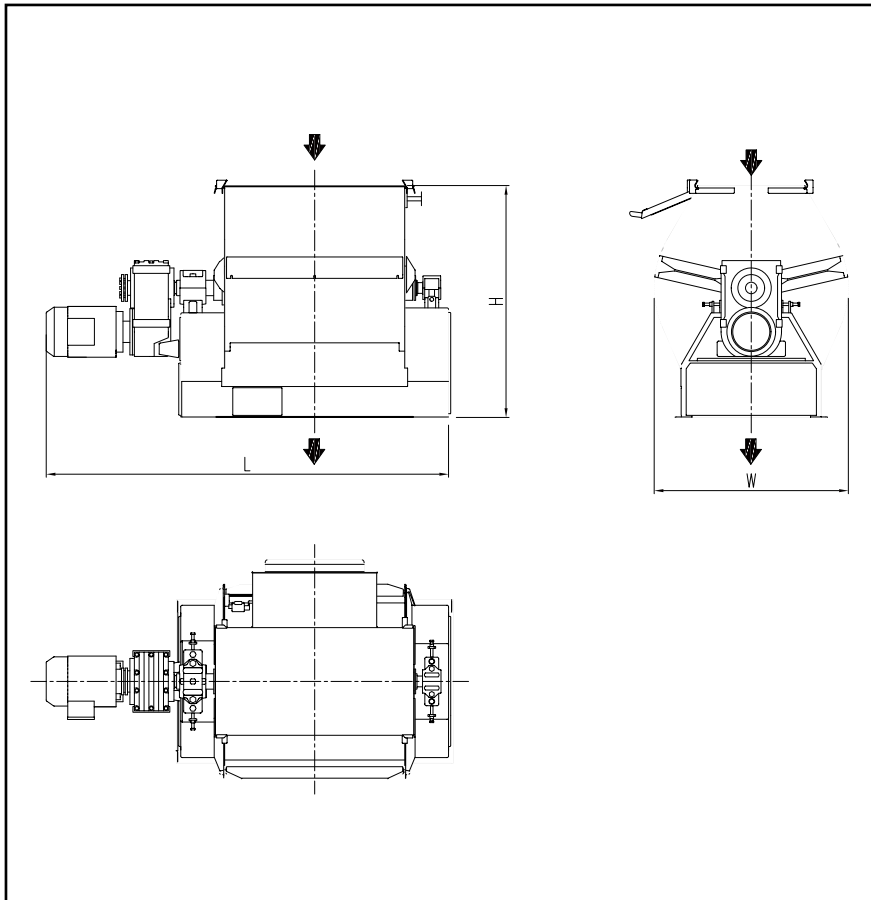

Model	Volume (m ³)	Air Consumption (L)	Power (kW)	Mixed Time (s)	Mixing Uniformity (cv.%)	Dimensions (L×W×H) (mm)
DHJ-1000	1	16	11/15	90	≤ 5	2578×1262×1504
DHJ-2000	2	32	18.5/22	90	≤ 5	2957×1564×1854
DHJ-4000	4	73	30/37	90	≤ 5	3609×1968×2345