

# GFJ

## HIGH PRESSURE FAN

This HIGH PRESSURE FAN features a carbon steel casing and a dynamically balanced rotor with radial blades set at optimal angles for maximum efficiency. The rotor is mounted on a cast-iron hub and directly driven by the motor shaft. Its dust-proof casing ensures stable performance, durability, and reliable operation under demanding industrial conditions—making it ideal for continuous use in grain, flour, and feed milling environments.



[info@g-grain.com](mailto:info@g-grain.com)

More details please visit [www.g-grain.com](http://www.g-grain.com) and download

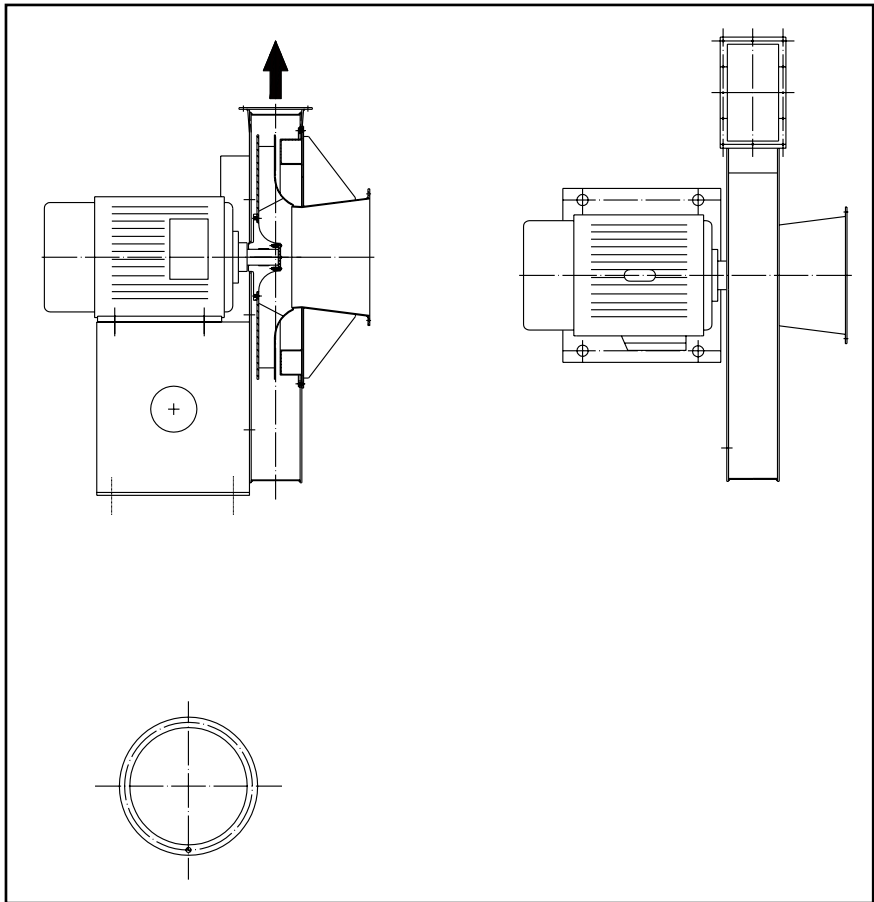

Model	Capacity (m <sup>3</sup> /h)	Pressure (Pa)	Power (kW)	Rotational Speed (r/min)
GFJ-7.3-1.5	7755-12881	9530-8930	37	2970
GFJ-7.7-1.5	7835-15189	10940-9910	45	2970
GFJ-8-1.8	10074-15978	11260-11080	55	2970
GFJ-8-1.8	16848-20092	11020-10080	75	2970
GFJ-8.4-2.4	13682-23951	12230-9720	75	2970
GFJ-8.4-2	12782-21646	12740-11270	75	2970
GFJ-8.4-2	21646-24767	11270-10110	90	2970
GFJ-8.8-2.5	15084-25118	13110-11200	90	2970
GFJ-7-19-5.6	1447-2653	6280-6160	7.5	2970
GFJ-7-19-6.3	2068-4135	8010-7660	11	2970
GFJ-7-19-6.3	4135-5169	7660-6740	15	2970
GFJ-7-19-6.5	2726-6814	9070-7220	18.5	2970
GFJ-7-19-7.1	2980-6456	10310-9520	22	2970
GFJ-7-19-7.1	6456-7449	9520-9680	30	2970
GFJ-7-19-8	4292-10729	13270-11170	45	2970