

ZBZ-6

CAROUSEL PACKER

This CAROUSEL PACKER is composed of loss-in-weight scales, feeding screw conveyor, carousel rotary table, sensors, bag clamp holder, posser, sewing machine, bag conveyor, and electronic and pneumatic control units. It is widely used for the automatic weighing and packing of powdery materials, supporting high-speed operations with precise target weight control.

The unloading device features vibration to ensure smooth material discharge. With rotary multi-spouts, the operator can remain in a fixed position to clamp bags without moving or waiting, maximizing packing efficiency.

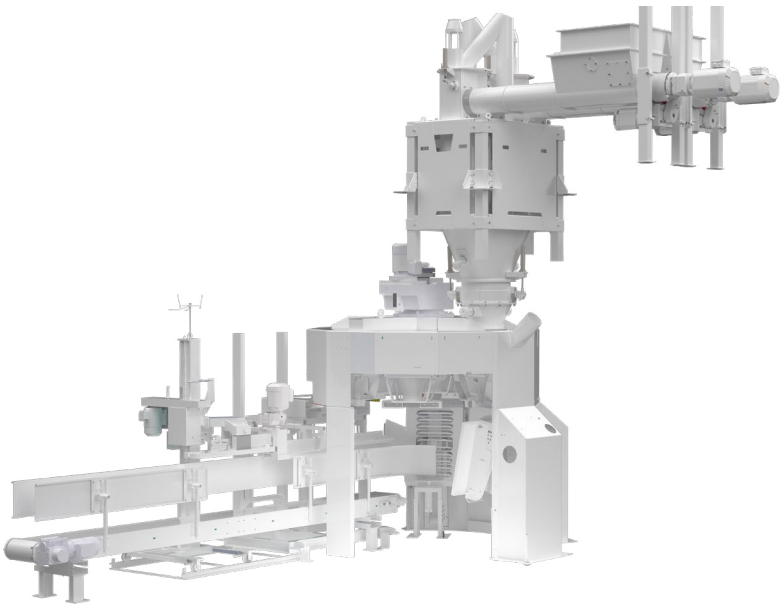

info@g-grain.com

More details please visit www.g-grain.com and download

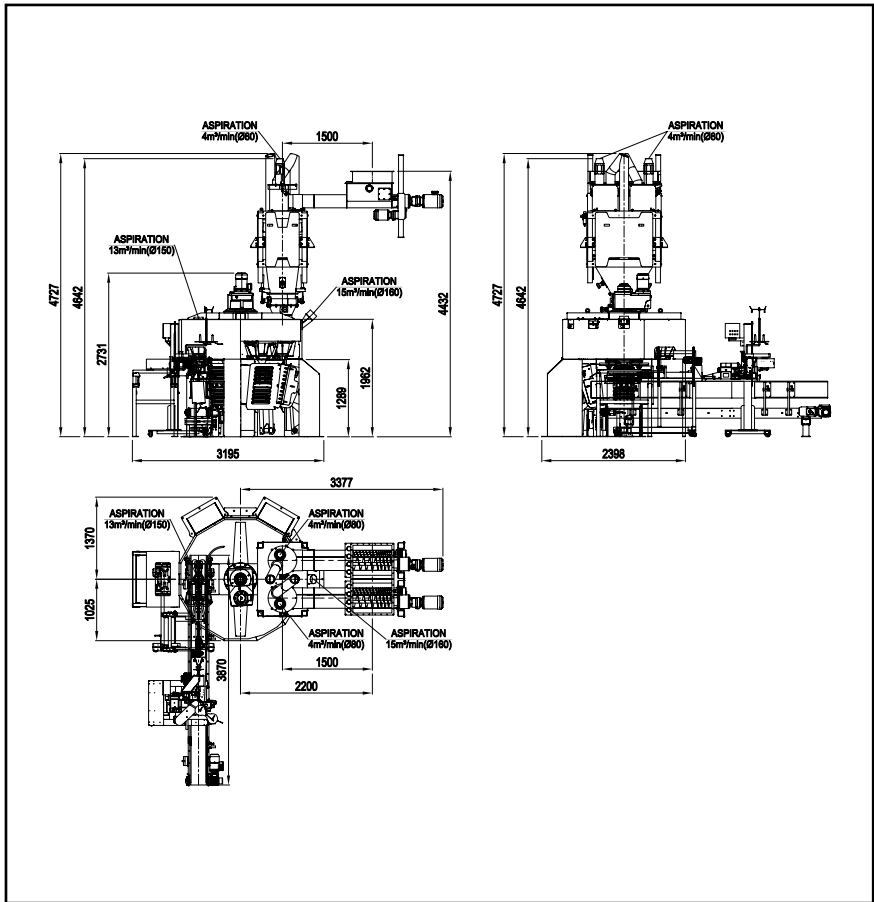

Model	Spout	Power (kW)	Capacity (bag/h)	Accuracy (%)	Air Pressure (MPa)	Air Consumption (m³/min)
ZBZ-4	4	2.2+2×1.1	500-600	±0.2	≥ 0.6	0.5
ZBZ-6	6	2.2+3×1.1	700-950	±0.2	≥ 0.6	0.6

Note: The packing speed depends on the weighing system, package weight, material, and operator.