

PTS

BUCKET ELEVATOR

This BUCKET ELEVATOR is designed for efficient vertical lifting of a wide range of materials including whole grains, flour, and bran. Its optimized structure ensures smooth conveying with minimal residue. Available with plastic or mild steel buckets to suit various applications, it offers reliable performance across grain, flour, and feed milling operations.

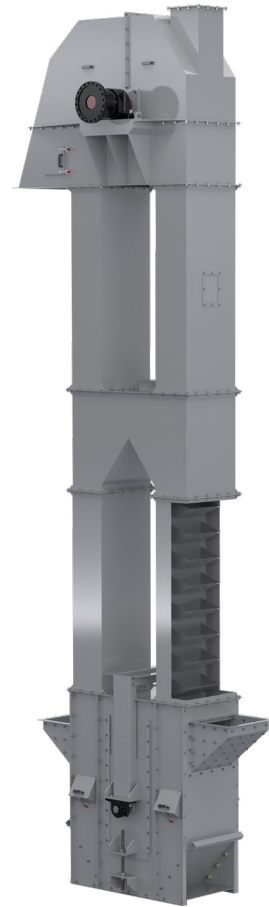

info@g-grain.com

More details please visit www.g-grain.com and download

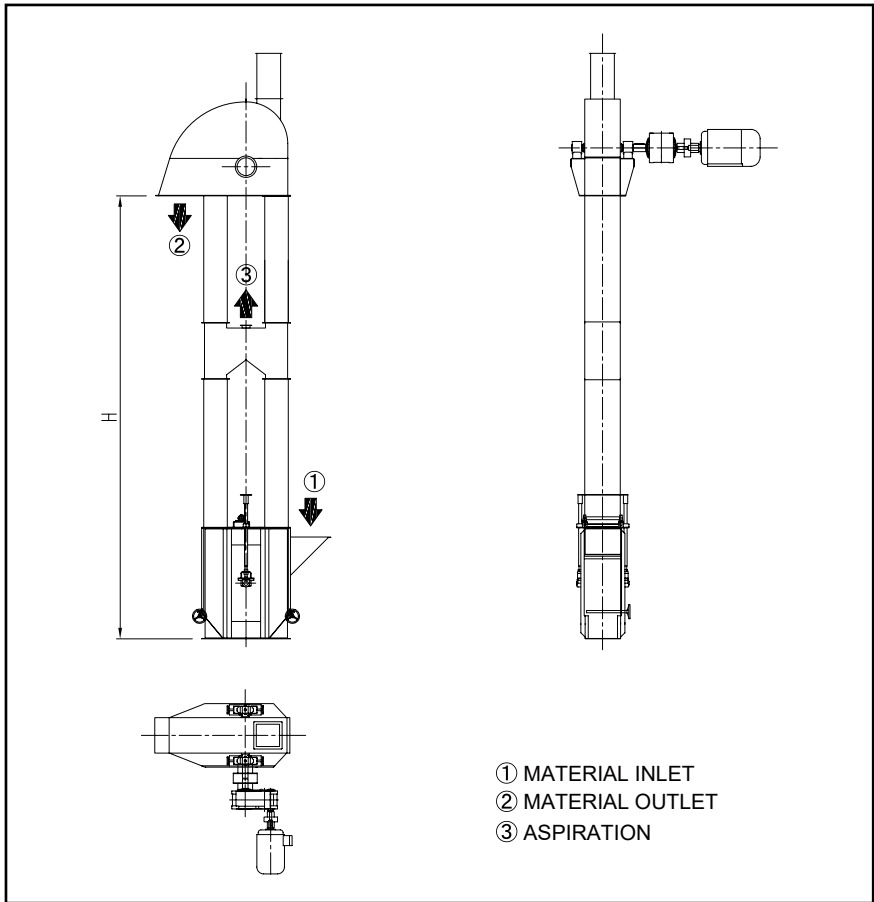

Model	Belt Speed (m/s)	Capacity (t/h)	Maximum Height (m)
PTS-50/28	2.0-2.8	50-80	45
PTS-60/33	2.5-3.3	100-150	50
PTS-80/46	2.5-3.3	200-250	60
PTS-80/56	2.5-3.3	250-350	60
PTS-100/33×2	2.5-3.5	350-550	60
PTS-100/46×2	2.5-3.5	450-650	60
PTS-100/56×2	2.5-3.5	600-800	60
PTS-120/56×3	2.5-3.5	900-1200	60

Note: Capacity is based on bulk density 0.75t/m³.